

**Refrigeration Equipment
2-Hinged Glass Door Full Height Ice
Cube Merchandiser Freezer 54
" Long**

ITEM # _____

MODEL # _____

NAME # _____

SIS # _____

AIA # _____



738322 (KCHGICM49FB)

2-Hinged Glass Door Full
Height Ice Cube
Merchandiser Freezer 54
" Long

Short Form Specification

Item No. _____

2-glass door freezer with exterior back, bottom, and top panels in galvanized steel, exterior side panels in painted steel; interior back, side, top in painted aluminum, and interior bottom panel in 304 stainless steel. Electronic control.

R290 gas in refrigeration circuit.
ETL Safety and Sanitation certified.
3/5Years warranty

Main Features

- External digital temperature display.
- Removable gasket for easy cleaning operations.
- Fin & Tube Condenser improves performance in high temperature environments.
- Automatic Defrost Cooling System provides worry-free performance.
- Electronic Temperature Control, quick and simple to set, with control display for easy monitoring.
- Cabinet completely insulated with high density polyurethane for low environmental impact.
- Back bottom mounted cooling unit guarantee an easy access and cleaning.

Construction

- Lockable door.
- Heavy duty casters.
- Magnetic gasket removable without tools for easy cleaning.
- Pre-wired heavy duty power cord.
- Heavy duty door hinges.

Sustainability

- CFC and HCFC free, highly ecological refrigerant type: R290 (ecological gas in foam: cyclopentane). Hydrocarbon refrigerant gas R290 for the lowest environmental impact (GWP=3), to reduce green house and ozone depletion effects.
- High efficiency components to minimize the energy consumption still guaranteeing the highest performances.

APPROVAL: _____

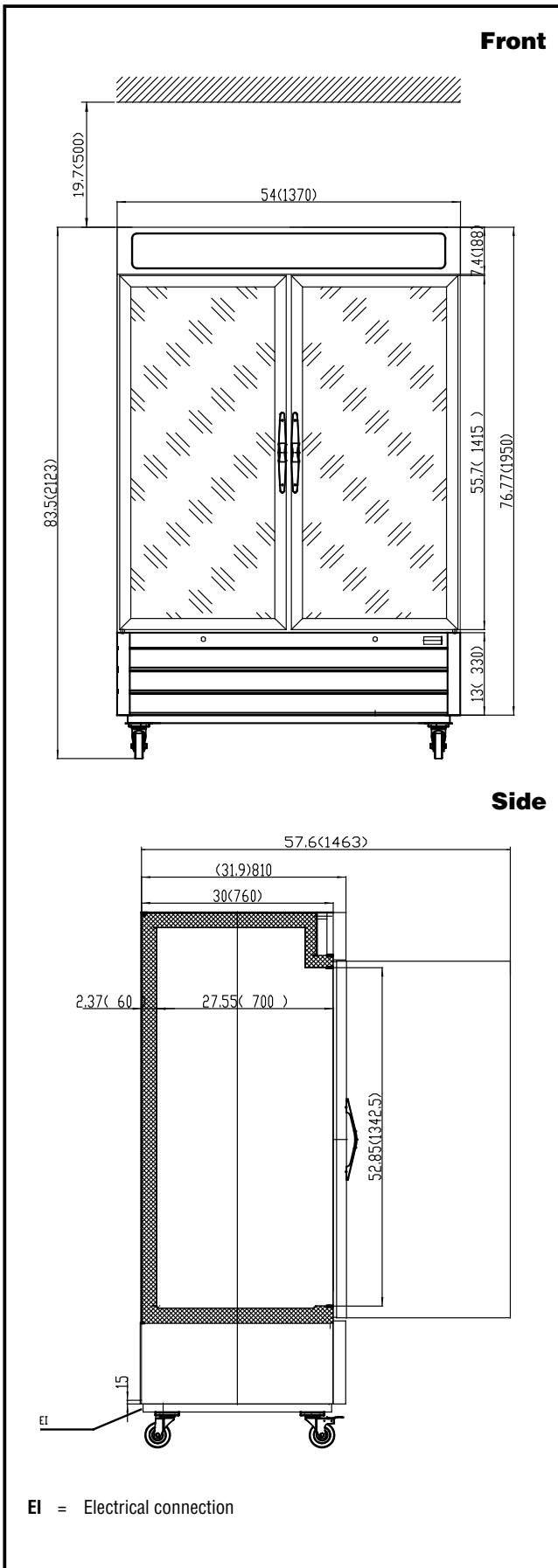

Electric

Supply voltage:	738322 (KCHGICM49FB)	115 V/1 ph/60 Hz
Electrical power, max:		1.08 kW
Plug type:		NEMA 5-15

Capacity:

Gross capacity:	47.2 cu.feet
-----------------	--------------

Key Information:

External dimensions, Width:	53 15/16" (1370 mm)
External dimensions, Depth:	31 7/8" (810 mm)
External dimensions, Height:	83 11/16" (2126 mm)
Internal Dimensions (depth):	27 1/2" (698.5 mm)
Internal Dimensions (height):	52 3/8" / (1330.96 mm)
Internal Dimensions (width):	49 3/8" / (1254.76 mm)
Shipping height:	85 13/16" (2180 mm)
Shipping weight:	580 lbs (263 kg)
Shipping volume:	96.06 ft ³ (2.72 m ³)
Type of external material:	Black Prepainted Steel
Type of internal material:	White Prepainted Aluminium
Warranty:	3 / 5 years
Approvals	ETL C&US;ETL SANITATION

Refrigeration Data

Compressor power:	1 1/4 hp
Operating temperature min.:	17.6 °F
Operating temperature max.:	23 °F
Condenser type:	Fin & tube
Defrost type:	Automatic

Sustainability

Current consumption:	9 Amps
Refrigerant type:	R290
GWP Index:	3
Refrigerant weight:	150 g